

X18T

**2500 W**  
1x 18" ACTIVE  
SUBWOOFER

Xcellence



WITH CWK-D

A new expression of the compact and powerful 18" subwoofer!  
The new cabinet design with laminar ports gets the most of the latest technology 18" transducer, making this subwoofer an ideal companion to X14T, X15T and X208 line array (stacked or flown).

## KEY FEATURES

### TRANSDUCER TECHNOLOGY

Active subwoofer composed by one 4-inch voice coil, neodymium magnet, last generation 18" loudspeaker front loaded in a bass-reflex tuned enclosure with laminar ports.

### AMPLIFICATION

2500 W 3rd generation Class D built-in amplifier, controlled by a dedicated DSP.

90% efficiency amplifier SMPS (switching mode power supply), allowing maximum power delivery with minimum consumption in an extremely low-weight and reduced size.

Rear connections and control panel with LCD screen to display the different settings, presets and adjustments done by the user. A capacitive keyboard guarantees the reliability of the system even under humidity and extreme weather conditions.

Exclusive and unique Overvoltage Protection which continuously monitors line voltage and instantly disconnects the system if the line voltage exceeds the maximum permissible level.

### DSP & CONTROL

Internal DSP with all necessary signal processing (crossovers, EQs, delay, limiters, gain control, mute) as well as several useful presets to adjust X18T to different requirements.

Ethernet connection and full wireless control: the system can be monitored from any spot in the room.

DSPStudio® control software capable of adjusting and setting-up even the finest details and monitoring key parameters of the amplifier: input and output levels, clip limiter activation, amplifier temperature and network connection status.

### DESIGN & ACCESSORIES

Connectors are placed on a 20° plane to increase protection against rain or moisture.

Several accessories allow easy flying. M20 plate socket provided at the top side for full-range enclosure stacking.

Ergonomic handles for an easy and comfortable transport.









Baltic birch plywood wooden cabinet with Polyurea® coating, offering maximum reliability and strength for touring as well as for high demanding applications.

# KR18T

**2500 W**  
1x 18" ACTIVE  
SUBWOOFER

*Xcellence*



-  **DSP STUDIO CONTROL APP FOR IPAD & WINDOWS**
-  **WITH CWK-D**
-  **CARDIOID PRESETS**
-  **LIGHT NEODYMIUM COMPONENTS**
-  **> 250 V OVERVOLTAGE PROTECTION**
-  **MULTIPLE PRESETS AVAILABLE**
-  **HIGH RESISTANT POLYUREA® PAINT**
-  **ACCESSORIES FOR EASY INSTALLATIONS**

**TECHNICAL FEATURES**

<b>Amplifier (program power)</b>	2500 W – Class D
<b>Input sensitivity</b>	2 dBu – 1 V
<b>Input Impedance</b>	20 kΩ Balanced
<b>Mains</b>	Universal Switch Mode Power Supply 85-265 V / 45-65 Hz
<b>Average current draw</b>	3.5 A (Heavy duty musical program)
<b>SPL (1 m)</b>	133 dB continuous, 136 dB peak
<b>Built-in DSP</b>	48 bit
<b>AD/DA converters</b>	24 bit – 96 kHz
<b>Presets</b>	LPF80+3 / LPF80+6 / LPF90+3 / LPF90+6 / LPF100+3 / LPF100+6 / LPF110+3 / LPF110+6 / LPF120+3 / LPF120+6 / CARDIOID + 23 configurable user memories
<b>Crossover frequency</b>	80 Hz / 90 Hz / 100 Hz / 110 Hz / 120 Hz
<b>Frequency response (-10 dB)</b>	32 Hz – 130 Hz
<b>Components LF</b>	18" neodymium woofer (4" voice coil)
<b>Directivity (HxV)</b>	Omnidirectional
<b>Directivity factor (Q)</b>	1
<b>Directivity index (DI)</b>	0
<b>Weight</b>	44.1 kg / 47.5 kg (with KR-18T flying kit)
<b>Dimensions (HxWxD)</b>	540 x 664 x 700 mm
<b>Finish</b>	Multilayer baltic birch plywood with high resistant black Polyurea® coating
<b>Grille</b>	1.5 mm steel with grey micro-foam cloth
<b>Rigging</b>	M6 points (for KR-18T rigging kit)
<b>Connectors</b>	1x XLR input / 1x XLR link / 1x AC PowerCon input / 1x AC PowerCon link / 1x EtherCon RJ45 input / 1x EtherCon RJ45 link



SIDE VIEW



FRONTAL VIEW WITHOUT GRILLE



REAR VIEW



BOTTOM VIEW



TOP VIEW



CONNECTION PANEL

# X18T

**2500 W**  
1x 18" ACTIVE  
SUBWOOFER

*Xcellence*



**BUILT-IN PRESETS**

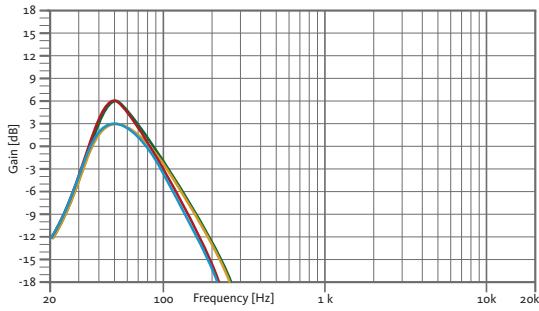

- LPF80+3**  
LPF 80 Hz + 3dB boost
- LPF80+6**  
LPF 80 Hz + 6dB boost
- LPF90+3**  
LPF 90 Hz + 3dB boost
- LPF90+6**  
LPF 90 Hz + 6dB boost
- LPF100+3**  
LPF 100 Hz + 3dB boost
- LPF100+6**  
LPF 100 Hz + 6dB boost

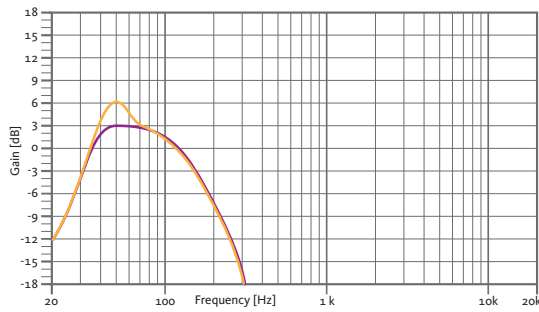
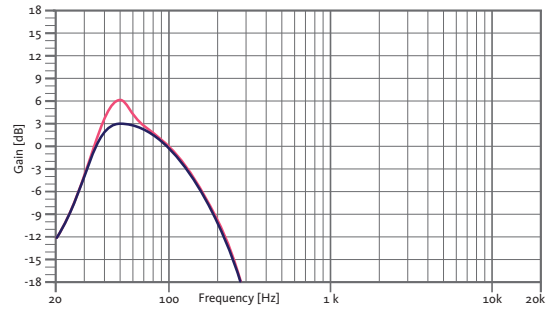

- LPF110+3**  
LPF 110 Hz + 3dB boost
- LPF110+6**  
LPF 110 Hz + 6dB boost
- LPF120+3**  
LPF 120 Hz + 3dB boost
- LPF120+6**  
LPF 120 Hz + 6dB boost

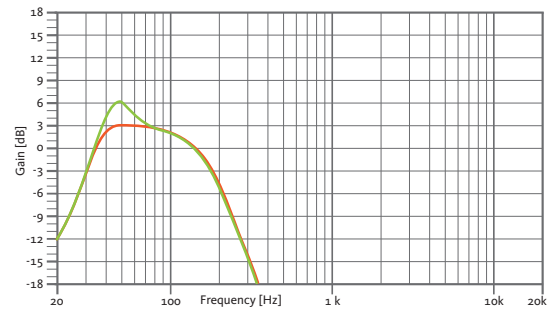

**FREQUENCY RESPONSE 1w/1m (LPF90+3 PRESET)**

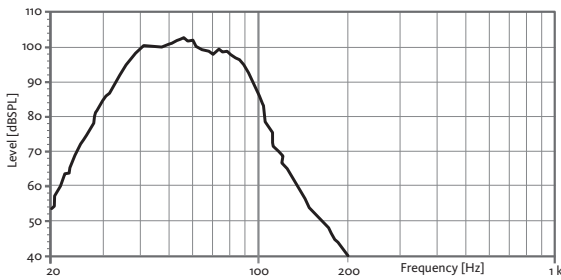

**CAD DRAWING SCHEME**

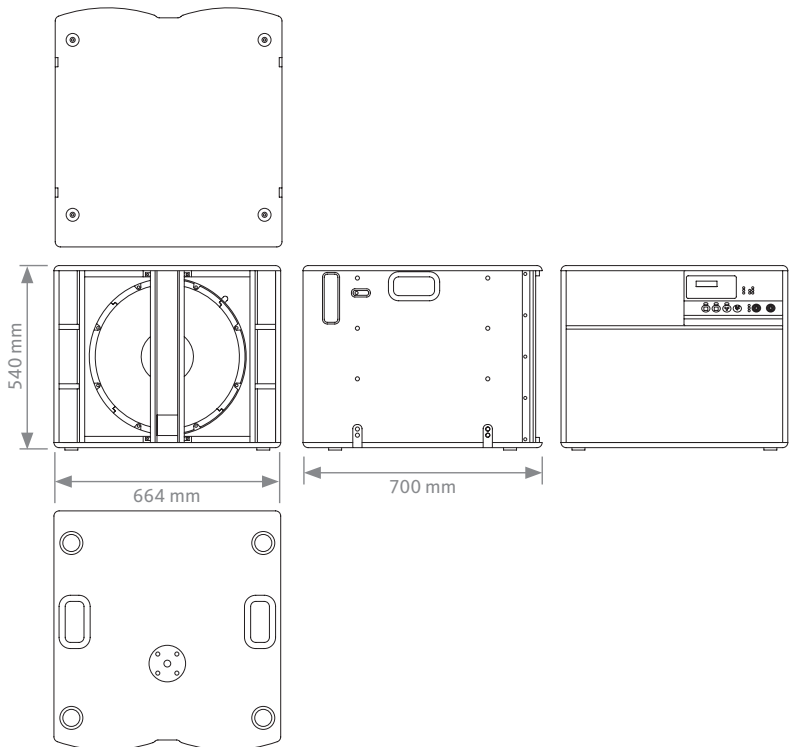

**EASY CARDIOID CONFIGURATION THROUGH DEDICATED PRESET**

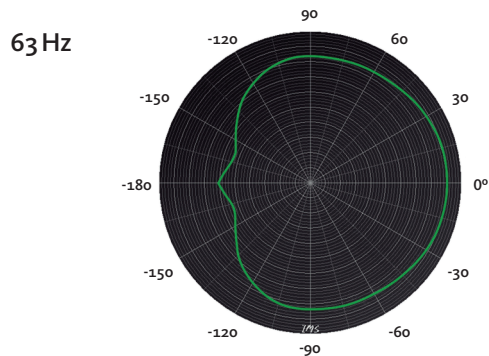

# X18T

**2500 W**  
1x 18" ACTIVE  
SUBWOOFER

*Xcellence*



**ACCESSORIES**

**FLIGHT CASE FC-X18T**

For one unit of X18T



**TOURING BUMPER TA-X208R**

For flying X18T



**FLYING HARDWARE KR-18T**

For flying X18T



**STACKING FRAME FR-X18**

For X18T underneath X208

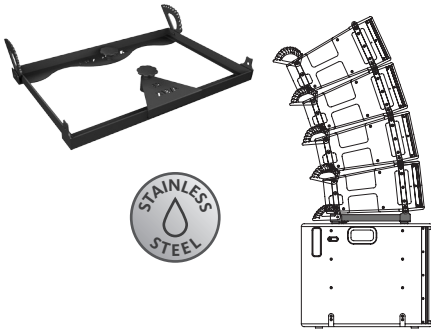

**DISTANCE ROD M20 SP-CRTL**

Ø: 35 mm Length: 55 cm ~ 90 cm Thread: M20



**WIRELESS COMMUNICATION KIT CWK-D**

Bespoke control protocol that supports Wi-Fi connectivity through CWK-D



**DSP STUDIO CONTROL SOFTWARE**



The application utilises a bespoke control protocol that supports Wi-Fi connectivity (control over IP).

It allows to address the ethernet-enabled amp and DSP modules in the Xcellence series cabinets, affording the user visual feedback on amplifier status and the ability to edit processor values from any spot in the venue.

You can edit parameters such as crossover frequency, gain (per way and separately mutable), limiter, polarity, delay, five custom parametric EQs or an array of filter shapes, can all be adjusted in fine detail, with several elements controllable at the same time using grouping functions.

The app also provides comprehensive information about input and output levels, heat-sink temperature, clip and protection indicators.

*"Instant access to outstanding sound"*

1

Configure your wifi network

2

Detect loudspeakers

3

Setup audio settings

4

Enjoy the best sound



iPad  
VERSION



PC  
VERSION

Download it from our website:  
[www.amateaudio.com](http://www.amateaudio.com)